

Wilmington, Delaware
December 5, 2024

#0512

Sponsor:

**Council
Member
Oliver**

WHEREAS, pursuant to City Charter Section 1-101, the City may acquire, hold, manage, and dispose of property on such terms as it deems proper for any municipal purpose; and

WHEREAS, City Code Section 2-627 authorizes the Department of Public Works, subject to the approval of Council by resolution, to grant such easements as shall be necessary to facilitate the construction, maintenance, operation, and/or repair of streets, roads, sidewalks, and/or other public rights-of-way; and

WHEREAS, the City currently owns the right-of-way at the 1000 block of North Orange Street (the “Right-of-Way”); and

WHEREAS, BPG Office Partners VIII LLC (“BPG”), the owner of the property adjacent to the Right-of-Way (namely 1007 North Orange Street, Wilmington, Delaware 19801, being Tax Parcel No. 26-028.40-096), would like to make certain improvements to a portion of the Right-of-Way including, but not limited to, the installation of a residential drop off lane, pavers, and curb cuts (collectively, the “Improvements”); and

WHEREAS, BPG has requested for the City to grant it an easement to accommodate the Improvements, as set forth in a proposed agreement between the City and BPG (the “Right-of-Way Easement Agreement”), a copy of which, in substantial form, is attached hereto and incorporated herein as Exhibit A; and

WHEREAS, City Council deems it necessary and appropriate to approve the grant of an easement to BPG as set forth in the Right-of-Way Easement Agreement.

NOW, THEREFORE, BE IT RESOLVED BY THE COUNCIL OF THE CITY OF WILMINGTON that the City's grant of an easement to BPG in the Right-of-Way for BPG to make the Improvements pursuant to the terms of the Right-of-Way Easement Agreement, a copy of which, in substantial form, is attached hereto and incorporated herein as Exhibit A, is hereby approved.

BE IT FURTHER RESOLVED that the Mayor, or his designee, is hereby authorized to execute any and all documents necessary to effectuate the grant of the easement, and the appropriate officers of the City are hereby authorized to take any and all further undertakings and assurances that may be appropriate.

Passed by City Council,

ATTEST: _____
City Clerk

SYNOPSIS: This Resolution approves the City's grant of an easement to BPG Office Partners VIII LLC in the right-of-way located at the 1000 block of North Orange Street to accommodate the construction and maintenance of certain improvements.

W0127051

EXHIBIT A

Tax Parcel Nos: 26-028.40-096 and
Portion of the Right-of-Way Comprising the
1000 Block of North Orange Street

Prepared by and Return to:
Elizabeth D. Power, Esquire
City of Wilmington Law Department
800 North French Street, 9th Floor
Wilmington, DE 19801

RIGHT-OF-WAY EASEMENT AGREEMENT

THIS RIGHT-OF-WAY EASEMENT AGREEMENT (this “Agreement”) is made this ____ day of _____, 2024 by and between the CITY OF WILMINGTON, a municipal corporation of the State of Delaware (the “Grantor” or the “City”), and BPG OFFICE PARTNERS VIII, LLC, a Delaware limited liability company (the “Grantee”).

WHEREAS, the Grantor owns the right-of-way located at the 1000 block of North Orange Street (the “Right-of-Way”);

WHEREAS, the Grantee owns an adjacent parcel of land and the building(s) situated thereon having an address of 1007 North Orange Street, Wilmington, Delaware 19801, being Tax Parcel No. 26-028.40-096 (the “Grantee’s Land”);

WHEREAS, the Grantee desires to make certain improvements to the Right-of-Way, including, but not limited to, installing a residential drop off lane, pavers, and curb cuts on a portion of the Right-of-Way, as detailed on Exhibit A, which is attached hereto and incorporated herein;

WHEREAS, the Grantee requires a permanent easement in the Right-of-Way in order to install and maintain such improvements; and

WHEREAS, the Wilmington City Council has approved by resolution the granting of the easement set forth in this Agreement.

NOW THEREFORE, the parties hereto, intending to be legally bound hereby and by the foregoing recitals, for good and valuable consideration, the receipt and sufficiency of which is hereby acknowledged, promise and agree to the following:

1. Easement. The Grantor hereby gives, grants, and conveys to the Grantee a non-exclusive easement over, upon, and across the Right-of-Way as specifically depicted in Exhibit “A” attached hereto and incorporated by reference herein (the “Easement”) in order to construct, install, maintain, repair, replace, and remove certain improvements, including, but not limited to, the installation and maintenance of a residential drop off lane, pavers, and curb cuts on a portion of the Right-of-Way, as more fully depicted on Exhibit “A” attached hereto and incorporated by reference herein (collectively, the “Improvements”).

2. Approval of the Commissioner of Public Works. The Grantee shall obtain the written approval of the Commissioner of Public Works (the “Commissioner”) prior to (i) installing each and every one of the Improvements, (ii) altering any of the Improvements, or (iii) removing any of the Improvements.

3. Installation and Maintenance of the Improvements. The Grantee shall be responsible, at the Grantee’s sole cost and expense, for the construction, installation, maintenance, repair, replacement, and removal of the Improvements.

4. Snow Removal. The Grantor shall not be responsible for any snow removal or repair within the Easement. The Grantee shall be responsible for any and all snow removal and repair in the Easement at the Grantee’s sole cost and expense.

5. Right of Grantor to Request Alteration or Removal of Certain Improvements. The Grantor shall have the right to require that the Grantee, at the Grantee’s sole cost and expense, alter or remove certain of the Improvements if the Commissioner deems such alteration or removal necessary for any public purpose or the event of an emergency. In such an event (except in the event of an emergency), the Grantor shall provide the Grantee with thirty (30) days’ written notice of such demand.

6. Reservation of Rights. The Grantor expressly retains for itself, any and all utilities, and members of the public full rights to the use of the Right-of-Way for any lawful purposes that do not interfere with, or impede the use of, the Easement granted to the Grantee herein, including by way of example but not limitation, the right to utilize the Right-of-Way for continued ingress, egress, and regress.

7. Abandonment of Easement; Default. If the Grantee, or its successors and permitted assigns, ever abandons the Improvements or defaults on its obligations under this Agreement, the Easement as set forth in Section 1 above shall automatically terminate, be null and void, and will no longer encumber the Right-of-Way of the Grantor. “Abandonment” has its plain and legal meaning but includes the following: the failure to maintain the Improvements to the standards required by all applicable statutes, ordinances, and regulations or if the Grantee ceases to use the building(s) on the Grantee’s Land for residential purposes. If the Grantee, or its successors and permitted assigns, abandons the Improvements or if this Agreement otherwise terminates, the Grantee, its successors or permitted assigns, shall, at the Grantee’s sole cost and expense, remove the Improvements and restore the Right-of-Way to its condition before the installation of the Improvements, or, alternatively, shall be liable to the Grantor for the full amount of the cost to the Grantor of restoring the Right-of-Way to its pre-installation condition, which total cost shall constitute a lien on the Grantee’s Land. The Grantee shall notify the Grantor in writing of its intent to abandon the Improvements at least ninety (90) days before it takes any action that is reasonably likely to cause an abandonment of the Improvements, or, if appropriate, immediately following the discovery of any change or condition that necessitates an abandonment of the Easement.

8. Termination of Easement by the Grantor. The Grantor shall have the right to terminate the Easement upon thirty (30) days’ written notice to the Grantee for any public purpose deemed

necessary by the Commissioner. The thirty-day notice requirement shall not apply to any situation deemed by the Commissioner to be an emergency.

9. No Encumbrances or Assignments. The Grantee shall not encumber or assign the Easement without the express prior written approval of the Grantor.

10. No Third-Party Beneficiaries. Notwithstanding anything contained in this Agreement to the contrary, this Agreement is solely for the benefit of the parties hereto, their successors and permitted assigns, and shall not benefit any third party or create or operate to create, either expressly or impliedly any rights, title, or interests hereunder in favor of any third party.

11. Indemnification. The Grantee shall defend, indemnify, and hold the Grantor, its officers, agents, and employees, safe and harmless from and against from any and all losses, costs, damages, claims, actions, or liabilities on account of the death or injury of any person or persons and/or any and all damage or destruction of any property on the Easement whenever such death, injury, property damage, or destruction arises from or grows out of the exercise of the Grantee's rights herein. This section shall survive any subsequent termination of this Agreement.

12. Insurance. The Grantee shall carry commercial general liability insurance with commercially reasonable limits of not less than One Million Dollars (\$1,000,000.00) with contractual liability sufficient to cover the Grantee's obligations pursuant to Section 11 of this Agreement. The Grantee shall name the Grantor as an additional insured on the Grantee's insurance policy. A copy of the certificate of insurance shall be provided to the Grantor.

13. Permits. The Grantee, at the Grantee's sole cost and expense, shall obtain all required permits for the construction, installation, use, maintenance, repair, replacement, and removal of the Improvements.

14. Applicable Law. The Grantee shall abide by all laws and regulations whatsoever in effect which govern the construction, installation, use, maintenance, repair, replacement, and removal of the Improvements. In the event the Grantee fails to comply with any such law or regulation, the Grantor shall be afforded all rights and remedies available at law, including, but not limited to, the right to cure any unlawful condition at the sole expense of the Grantee, and, in its discretion, to terminate this Agreement and the Easement it grants.

15. Notices. All notices under this Agreement shall be in writing and sent prepaid by (i) certified mail, return receipt requested, (ii) overnight courier of national or regional recognition (such as UPS or Federal Express) or (iii) personal delivery or courier. The written notice shall to the extent practicable cite to the applicable term of this Agreement and must in all cases be accompanied by a copy of the fully executed Agreement:

(a) If intended for the City of Wilmington (the Grantor):
City of Wilmington
Department of Public Works
800 North French Street, Sixth Floor
Wilmington, DE 19801
Attn: Commissioner

- with a copy to -

City of Wilmington
Law Department
800 North French Street, Ninth Floor
Wilmington, DE 19801
Attn: City Solicitor

(b) If intended for BPG Office Partners VIII LLC (the Grantee):

Attn:

16. Miscellaneous.

(a) If any provision of this Agreement, or the application thereof to any person or circumstances, is or shall be held invalid or unenforceable, the remainder of this Agreement, or the application of such provision to any other persons or circumstances, shall not be affected thereby.

(b) The section headings in this Agreement are for convenience only, do not define or limit the scope or content of this Agreement, and shall not be considered in any construction or interpretation of this Agreement or any part thereof.

(c) This Agreement shall be binding upon the parties and their successors and permitted assigns in title and inure to the benefit of the parties and their employees, successors, permitted assigns, independent contractors, and agents and its terms shall run with the land.

(d) This Agreement shall be governed and construed in accordance with the laws of the State of Delaware. All disputes in connection with this Agreement shall be resolved by a court of competent jurisdiction located New Castle County, Delaware.

(e) This Agreement constitutes the entire agreement between the parties, and any prior understanding or representation of any kind preceding the date of this Agreement shall not be binding on either party except to the extent incorporated in this Agreement.

(f) This Agreement may not be modified, changed, or supplemented, nor may any of the obligations and rights be waived, except by written instrument signed by both parties to this Agreement.

(g) This Agreement may be executed in one or more counterparts, and all counterpart-signed documents shall be deemed to be an original and one (1) instrument.

(h) This Agreement shall be recorded in the office of the Recorder of Deeds for New Castle County, Delaware.

[signature page follows]

IN WITNESS WHEREOF, the parties executed this Agreement under seal on the date first above written.

CITY OF WILMINGTON

Witness

By: _____ (SEAL)
Name: Kelly A. Williams
Title: Commissioner of Public Works

[CORPORATE SEAL]

State of Delaware)
) ss.
County of New Castle)

On this _____ day of _____, 2024, there did appear before me, a Notary Public for the State and County aforesaid, Kelly A. Williams, Commissioner of Public Works of the City of Wilmington, who did execute the foregoing Right-of-Way Easement Agreement on behalf of the City of Wilmington.

Notary Public

[signatures continue on next page]

BPG OFFICE PARTNERS VIII LLC

Witness

By: _____ (SEAL)
Name:
Title:

[CORPORATE SEAL]

State of Delaware)
) ss.
County of New Castle)

On this _____ day of _____, 2024, there did appear before me, a Notary Public for the State and County aforesaid, _____, the _____ of BPG OFFICE PARTNERS VIII, LLC, who did execute the foregoing Right-of-Way Easement Agreement on behalf of the BPG OFFICE PARTNERS VIII LLC.

Notary Public

EXHIBIT A

ORANGE STREET IMPROVEMENTS CIVIL - 100% CONSTRUCTION DOCUMENTS

EXISTING DETAIL

	SURVEY TRAVERSE POINT	(TYPE LABEL)	CURB
	POINT OF TANGENCY & CURVATURE	(TYPE LABEL)	INTEGRAL CURB & GUTTER
	SURVEY TIE POINT LOCATION	---	FLEXIBLE PAVEMENT EDGE
	BENCH MARK LOCATION	---	RIGID PAVEMENT EDGE
	SOIL BORING LOCATION - PLAN VIEW	---	STEEL BEAM GUARD RAIL
	MARSH OR WET AREAS	---	WOOD POST AND CABLE GUARD RAIL
	LAWN	D.I.	STORM DRAINAGE SURFACE INLET
	SMALL BUSH OR ORNAMENTAL SHRUB	Ⓟ	STORM DRAINAGE MANHOLE
	CONIFEROUS TREE 6" AND LARGER	J.B.	STORM DRAINAGE JUNCTION BOX
	DECIDUOUS TREE 6" AND LARGER	(SIZE / TYPE / LABEL)	EXISTING DRAINAGE PIPE AND FLOW ARROW
	HEDGEROW OR THICKET	---	DRAINAGE PIPE HEADWALL
	WOODS LINE	---	EROSION CONTROL STONE
	GAS MANHOLE	---	STREAM, DITCH OR POND BOUNDARY
	SANITARY SEWER MANHOLE	---	STREAM FLOW DIRECTION ARROW
	TELEPHONE MANHOLE	SIGN	TRAFFIC CONTROL SIGN POST
	ELECTRIC MANHOLE	Ⓜ	TRAFFIC SIGNAL SUPPORT BASE
	FIRE HYDRANT	Ⓜ	TRAFFIC SIGNAL CONTROL BOX AND/OR BASE
	TELEPHONE BOOTH	J.W.	TRAFFIC SIGNAL CONDUIT JUNCTION WELL
	UTILITY POLE GUY WIRE ANCHOR	Ⓜ	ELECTRIC TRANSFORMER
	GAS VALVE	Ⓜ	CABLE TELEVISION DISTRIBUTION BOX
	WATER VALVE	C.M.	CONCRETE MONUMENT OR PROPERTY MARKER
	WOOD POLE	I.P.	PROPERTY LINE MARKER
	WATER METER	---	STONE PILLAR - CONC. BLOCK OR POURED
	SANITARY SEWER VENT	---	STRAND OR WOVEN WIRE FENCE
	SANITARY SEWER SURFACE FIXTURE	---	WOODEN FENCE
	TELEPHONE TEST POINT	Ⓜ	LUMINAIRE SUPPORT POLE AND/OR BASE
	GAS METER	R/W	EXISTING RIGHT OF WAY
	POLE MOUNTED LUMINAIRE	---	EXISTING PROPERTY LINE

ABBREVIATIONS

AE	- AERIAL EASEMENT	GRC	- GRANITE CURB	RT.	- RIGHT
A/R	- AXIS OF ROTATION	G.V.	- GAS VALVE	S, SAN.	- SANITARY
ASPH	- ASPHALT	H.G.	- HYDRAULIC GRADIENT	SD	- STORM DRAIN
BIT.	- BITUMINOUS	H.P.	- HIGH POINT	S/E	- SUPERELEVATION
B	- BASELINE OF CONSTRUCTION	HSA	- HOLLOW STEM AUGER	SECT.	- SECTION
BLVD.	- BOULEVARD	INV.	- INVERT	SHLD.	- SHOULDER
B.M.	- BENCH MARK	IRR.	- IRRIGATION	S.H.P.	- STEEL HIGH PRESSURE
C	- CABLE TV CUT	J.B.	- JUNCTION BOX	SHT.	- SHEET
C.B.	- CATCH BASIN	J.W.	- JUNCTION WELL	ST, ST'L.	- STEEL
C/C	- CENTER TO CENTER	L	- LENGTH LIGHTING	STA.	- STATION
CC	- CONCRETE CURB	LANDSC.	- LANDSCAPING	STD.	- STANDARD
CC&G	- CONCRETE CURB & GUTTER	L.B.	- LAWN BASIN	STY	- STORY
CC	- CONCRETE GUTTER	LEV.	- LEVEL	S.V.	- SANITARY VENT
CHW	- CONCRETE HEADWALL	L.F.	- LINEAR FEET	SW	- SIDEWALK
CIP	- CAST IRON PIPE	LP	- LOW POINT	SWM	- STORMWATER MANAGEMENT
CL	- CLEAR	L.S.	- LUMP SUM	T	- TANGENT TELEPHONE
C	- CENTERLINE	LT.	- LEFT	TC	- TERRAZZO
CLF	- CHAIN LINK FENCE	MAX.	- MAXIMUM	T/C	- TOP OF CURB ELEVATION
C.M.	- CONCRETE MONUMENT	MC.	- METAL COVER	T-D	- TELEPHONE DIRECT BURIAL CABLE
CMP	- CORRUGATED METAL PIPE	MET	- METAL	TEMP.	- TEMPORARY
CMPA	- CORRUGATED METAL PIPE ARCH	MGR	- MODIFIED GUARDRAIL	T.G.	- TOP OF GRATE
CON.	- CONSTRUCTION	MIN.	- MINIMUM	TH	- TEST HOLE
CONC.	- CONCRETE	MOD.	- MODIFIED	TMH	- TOP OF MANHOLE
CP	- CONCRETE PIPE	NAP	- NO ASSOCIATED PIPING	T.P.	- SURVEY TIE POINT
CSW	- CONCRETE SIDEWALK	N/C	- NORMAL CROWN	TRANS.	- TRANSMISSION
C.T.O.C.	- CENTER TO CENTER	O.D.	- OUTER DIAMETER	TRM	- TEMPORARY ROADWAY MATERIAL
DATR	- DETERMINED ACCORDING TO RECORDS	OH	- OVERHEAD	TYP.	- TYPICAL
DB	- DIRECT BURIAL	ORN.	- ORNAMENTAL	UG	- UNDERGROUND
DBC	- DIRECT BURIAL CABLE	P.C.	- POINT OF CURVATURE	V	- VALVE
D.D.H.	- DELAWARE DEPARTMENT OF HIGHWAYS	P.C.C.	- POINT OF COMPOUND CURVE	VAR.	- VARIABLE
DEPR.	- DEPRESSED	P.C.C.	- PORTLAND CEMENT CONCRETE	V.C.	- VALVE COVER
DH	- DRILL HOLE	P/GA	- POINT OF GRADE APPLICATION	VCP	- VITRIFIED CLAY PIPE
DI	- DRAINAGE INLET	PSL	- POINT OF INTERSECTION	VCPX	- VITRIFIED CLAY PIPE EXTRA STRENGTH
D.I.P.	- DUCTILE IRON PIPE	PI	- POINT OF INTERSECTION	W	- WATER
DISTR.	- DISTRIBUTION	PK	- PK NAIL	W/	- WITH
DWLG.	- DWELLING (HOUSE)	P.O.C.	- POINT ON CURVE	WL	- WETLANDS
E	- EXTERNAL ELECTRICAL	P.O.T.	- POINT ON TANGENT	W.M.	- WATER METER
E-D	- ELECTRICAL DIRECT BURIAL CABLE	P.O.V.T.	- POINT ON VERTICAL TANGENT	WSE	- WATER SURFACE ELEVATION
EDA	- EXISTING DENIAL OF ACCESS LINE	PROP.	- PROPOSED	W.V.	- WATER VALVE
EL.	- ELEVATION	P.T.	- POINT OF TANGENCY	YR.	- YEAR
ELLIP.	- ELLIPTICAL	P.V.C.	- POINT OF VERTICAL CURVATURE	Δ	- CENTRAL ANGLE
ENTR.	- ENTRANCE	P.V.R.C.	- POINT OF VERTICAL REVERSING CURVE		
EPE	- EXISTING PERMANENT EASEMENT	P.V.T.	- POINT OF VERTICAL TANGENCY		
E.S.S.C.	- EROSION AND SEDIMENT CONTROL	R	- RADIUS		
EX-EXIST.	- EXISTING	RCEP	- REINFORCED CONCRETE ELLIPTICAL PIPE		
F	- FILL	RCP	- REINFORCED CONCRETE PIPE		
F.H.	- FIRE HYDRANT	RCPX	- REINFORCED CONCRETE PIPE EXTRA STRENGTH		
F.O.	- FIBER OPTIC	RCSP	- REINFORCED CONCRETE SEWER PIPE		
G	- GAS	RD.	- ROAD		
G.M.	- GAS METER	RDWY.	- ROADWAY		
GR.	- PROPOSED PROFILE GRADE ELEVATION	RNDG.	- ROUNDING		

DRAWING INDEX

C-100	INDEX PLAN
C-111	EXISTING CONDITIONS PLAN (N. ORANGE STREET)
C-121	DEMOLITION PLAN (N. ORANGE STREET)
C-201	SITE PLAN (N. ORANGE STREET)
C-210	SITE DETAILS
C-301	GRADING PLAN (N. ORANGE STREET)
C-311	GRADING STAKEOUT PLAN (N. ORANGE STREET)
C-401	UTILITY COMPOSITE PLAN (N. ORANGE STREET)
C-410	UTILITY DETAILS
SWM-01	STANDARD PLAN - COVER SHEET AND GENERAL NOTES
SWM-02	STANDARD PLAN - CONSTRUCTION SITE STORMWATER MANAGEMENT PLAN
SWM-03	STANDARD PLAN - CONSTRUCTION SITE STORMWATER MANAGEMENT DETAILS

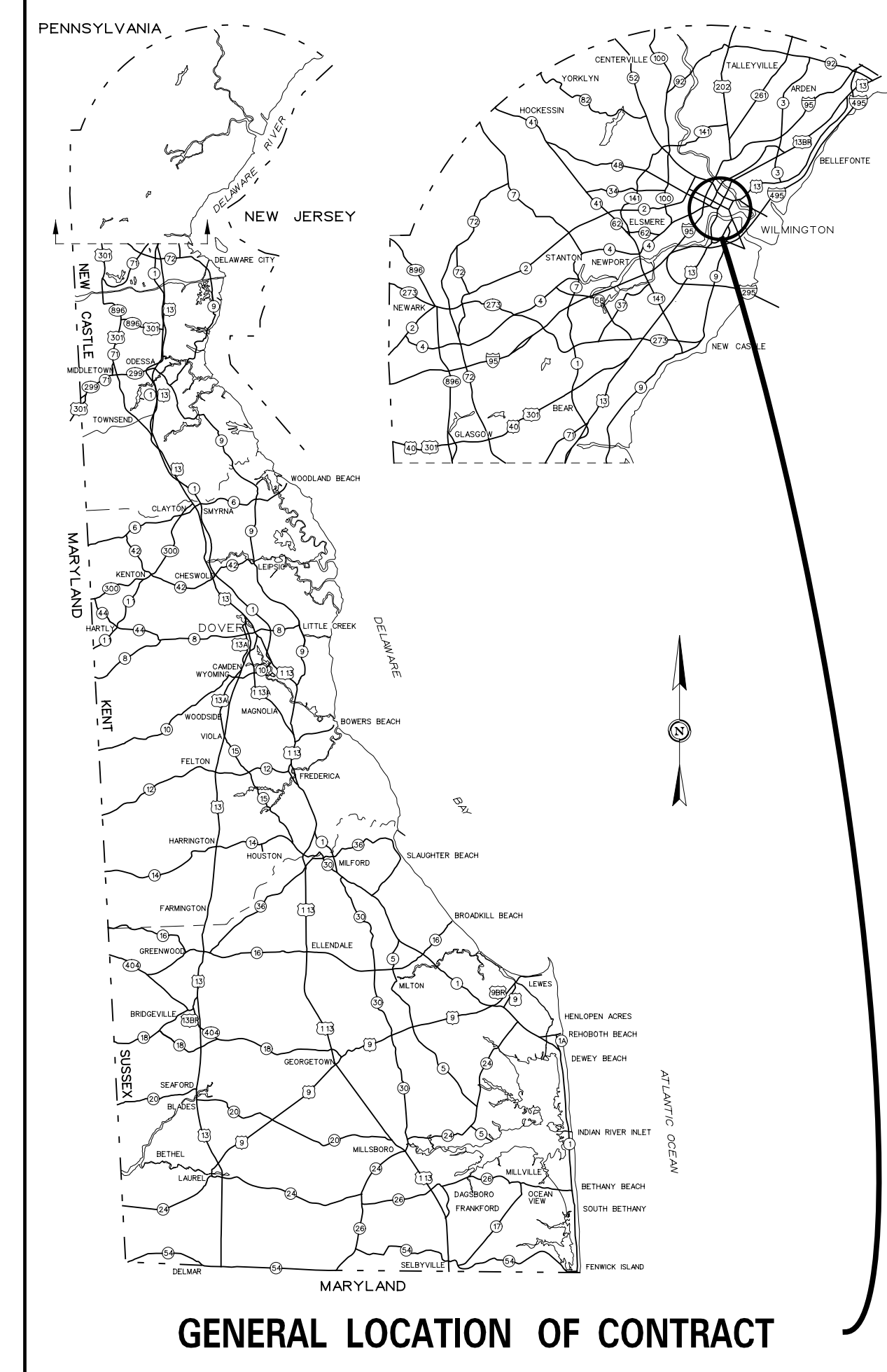

GENERAL LOCATION OF CONTRACT

GENERAL NOTES:

- THE TOPOGRAPHIC AND THE UTILITY INFORMATION SHOWN HEREON WAS OBTAINED FROM SURVEYS CONDUCTED BY KARINS AND ASSOCIATES IN MARCH 2023 AND MAY NOT REFLECT CURRENT CONDITIONS. IT IS THE RESPONSIBILITY OF THE CONTRACTOR TO VERIFY CURRENT TOPOGRAPHIC AND UTILITY INFORMATION TO HIS/HER OWN SATISFACTION. THE DATUM USED ON THIS PROJECT IS HORIZONTAL- NAD (83/2011) AND VERTICAL NAVD (88).
- THE PROPERTY LINES SHOWN HEREON MAY NOT REFLECT CURRENT CONDITIONS.
- PROPERTY ADDRESS:
1007 NORTH ORANGE STREET
WILMINGTON, DELAWARE 19801
- LIMIT OF CONSTRUCTION AS SHOWN ON THIS PLAN AND ALL CIVIL DRAWINGS IS APPROXIMATE AND SHALL NOT PREVENT THE CONTRACTOR FROM EXTENDING BEYOND THESE LIMITS FOR COMPLETE INSTALLATION OF PROJECT ELEMENTS. ALL EXISTING FEATURES OUTSIDE THE LIMIT OF DISTURBANCE ARE TO REMAIN, UNLESS OTHERWISE NOTED. ITEMS OUTSIDE THESE LIMITS THAT ARE DAMAGED OR REMOVED BY THE CONTRACTOR SHALL BE RETURNED TO PRE-DEMOLITION CONDITIONS OR REPLACED AT NO ADDITIONAL COST TO THE OWNER.
- REFER TO EROSION AND SEDIMENT CONTROL PLANS FOR SEQUENCE OF OPERATIONS BEFORE INITIATING DEMOLITION ACTIVITY.
- LOCATIONS OF INDIVIDUAL ELECTRIC, TELEPHONE, GAS, WATER AND SANITARY SEWER SERVICE CONNECTIONS AS SHOWN HEREON ARE UNCERTAIN. THE LOCATION OF S&D CONNECTIONS HAS BEEN FIELD LOCATED WHERE POSSIBLE, BUT IN CASES WHERE THE LINES HAVE BEEN CONSTRUCTED AND PAVED OVER THE CONNECTIONS ARE BASED ON PROPOSED SITE PLANS OR AN ESTIMATION OF POSSIBLE LOCATIONS. SHOULD EXCAVATION BECOMES NECESSARY FOR MAINTENANCE OR REPAIR OF THESE LINES, IT IS THE CONTRACTOR'S RESPONSIBILITY TO ACCURATELY DETERMINE THE LOCATION OF THESE LINES BEFORE COMMENCING WORK. CONTACT "MISS UTILITY" AT 1-800-282-8555 PRIOR TO ANY EXCAVATION.
- TEST PITS ARE REQUIRED ON THIS PROJECT TO LOCATE ALL EXISTING UNDERGROUND UTILITIES. THE CONTRACTOR, PRIOR TO LAYING A RUN OF PIPE OR EXCAVATING FOR ANY UTILITY APPURTENANCE, SHALL EXCAVATE WITHIN THE ALIGNMENT AT POINTS OF POSSIBLE CONFLICT TO DETERMINE IF A CONFLICT EXISTS. ANY CONFLICTS SHALL BE COORDINATED BY THE CONTRACTOR WITH THE ENGINEER, AND THE CONSTRUCTION MANAGER, TO DETERMINE A SOLUTION.
- AS-BUILT PLANS ARE REQUIRED FOR ALL STORM DRAINAGE.
- ALL CONSTRUCTION WITHIN THE STREET RIGHT-OF-WAYS WILL BE CONSTRUCTED TO THE MOST CURRENT CITY OF WILMINGTON AND DELDOT DETAIL STANDARDS AND SPECIFICATIONS.
- ALL SIDEWALKS AND BRICK PAVERS IMPACTED BY THE SITE/UTILITY CONSTRUCTION SHALL BE REPLACED IN KIND. ALL CURB RAMPS IMPACTED BY THE SITE/UTILITY CONSTRUCTION SHALL BE REPLACED WITH CURB RAMPS THAT MEET CURRENT ADA STANDARDS. ALL CURBS IMPACTED BY THE SITE/UTILITY CONSTRUCTION SHALL BE REPLACED IN KIND, UNLESS OTHERWISE NOTED.
- ALL HANDICAP ACCESSIBLE WALKWAYS ARE REQUIRED TO HAVE CROSS-SLOPES EQUAL TO OR LESS THAN 2%.
- ANY DAMAGE CAUSED TO ROADS, CURBS, HOT-MIX, SIGNS, UTILITIES, ETC. WITHIN THE STREET RIGHT-OF-WAYS DURING THE COURSE OF CONSTRUCTION WILL BE REPAIRED OR REPLACED TO THE SATISFACTION OF THE CITY OF WILMINGTON AT THE CONTRACTOR'S EXPENSE.
- THE EXISTING PARCEL NUMBER IS 26-028.40-096 AND THE LOT SIZE IS 1.81 ACRES. THE DISTURBED AREA IS 0.24 ACRES.

OWNER
BPGS (BUCCINI | POLLIN GROUP)
1000 N. West Street, Suite 850
Wilmington, DE 19801
v 302.691.2101

CIVIL ENGINEER
R&K
700 East Pratt Street, Suite 500
Baltimore, MD 21202
v 410.913.8521
www.rkk.com

1	7/14/2023	REV. PER BPGS COMMENTS

Δ	DATE:	DESCRIPTION:

ORANGE STREET IMPROVEMENTS

PROJECT #:	23049
SCALE:	N.T.S.
FORMAT:	30" X 42"
DRAWN:	WDK
CHECKED:	MPJ
DATE:	May 3, 2024

SHEET NAME: INDEX PLAN

SHEET NUMBER:
C-100
NOT FOR CONSTRUCTION
PROJECT PHASE:
CONSTRUCTION DOCUMENTS

OWNER
BPGS (BUCCINI / POLLIN GROUP)
1000 N. West Street, Suite 850
Wilmington, DE 19801
v.302.691.2101

CIVIL ENGINEER
RK&K
700 East Pratt Street, Suite 500
Baltimore, MD 21202
v.410.913.8821
www.rk.com

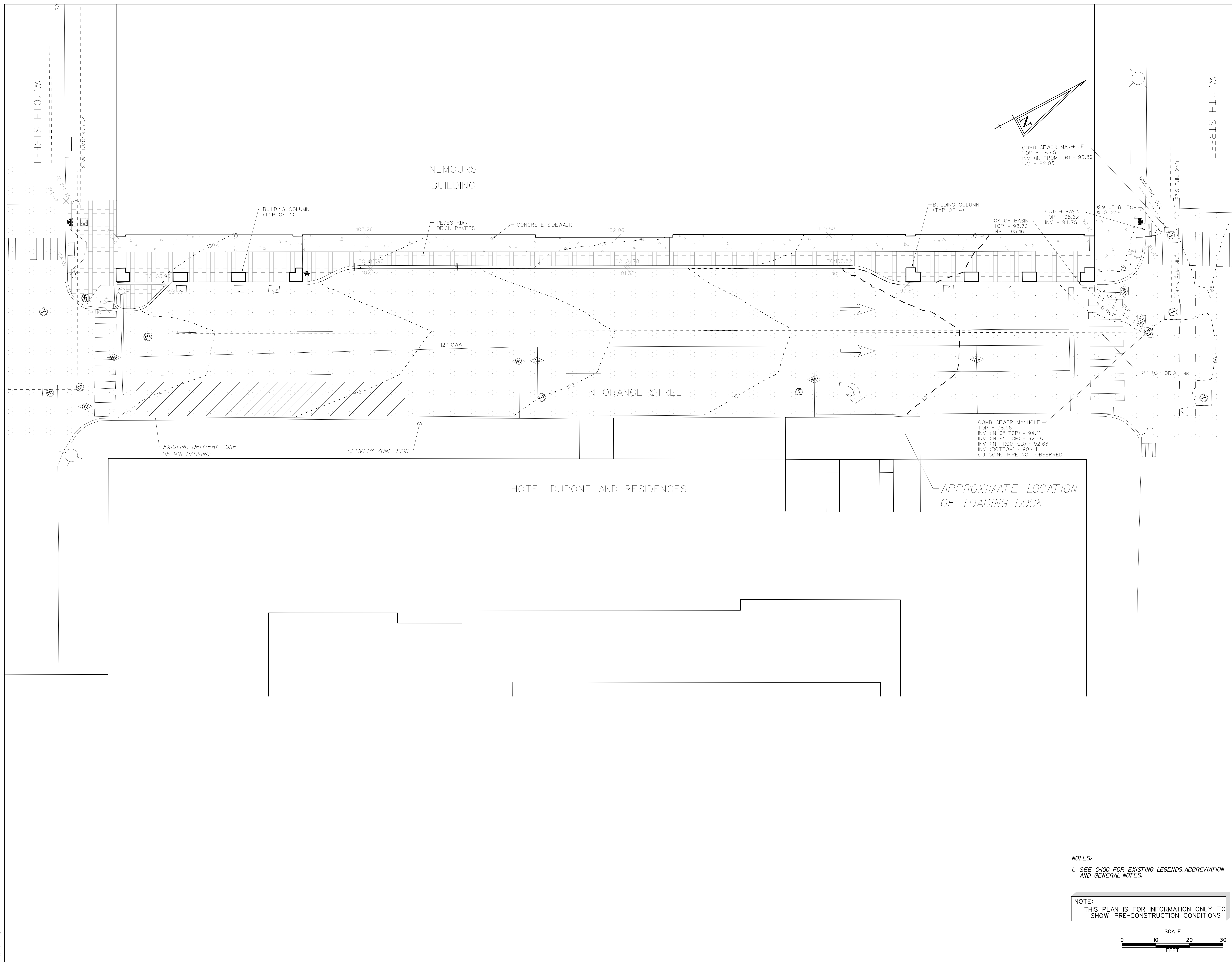

ORANGE STREET IMPROVEMENTS

PROJECT #:	23049
SCALE:	1"=10'
FORMAT:	30" X 42"
DRAWN:	WDK
CHECKED:	MPJ
DATE:	May 3, 2024

SHEET NAME:

EXISTING CONDITIONS PLAN (N. ORANGE STREET)

SHEET NUMBER:

C-111

NOT FOR CONSTRUCTION

PROJECT PHASE:

CONSTRUCTION DOCUMENTS

\\server\k&k.com\Fa\Cloud\Projects\2023\23049-NB\A\Cadd\Plans\CD_CITL_CD_NBI.dgn
11:00:34 AM

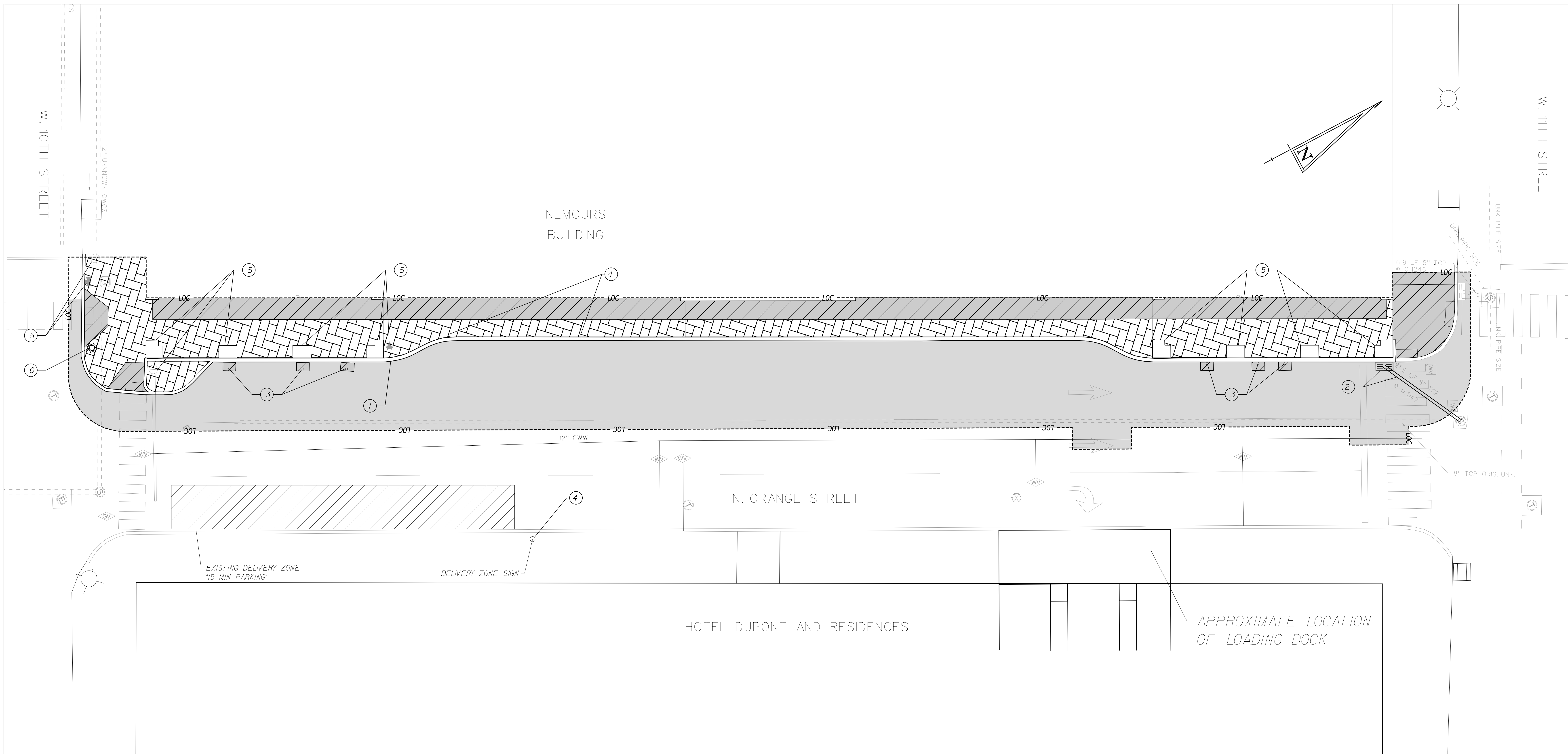

OWNER
BPQS (BUCCINI | POLLIN GROUP)
 1000 N. West Street, Suite 850
 Wilmington, DE 19801
 v.302.691.2101

CIVIL ENGINEER
RK&K
 700 East Pratt Street, Suite 500
 Baltimore, MD 21202
 v.410.913.8521
 www.rkk.com



EXISTING PIPES SHOWN AS BOLD ARE TO BE PLUGGED AND FILLED WITH FLOWABLE FILL

LEGEND

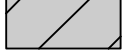
-  ASPHALT REMOVAL
-  BRICK PAVER REMOVAL (PAVERS TO BE SALVAGED FOR REUSE)
-  CONCRETE SIDEWALK REMOVAL

KEY NOTES

- ① EXISTING CONCRETE CURB TO BE REMOVED. CONTRACTOR SHALL SAW CUT CURB AT 6" BELOW TOP OF CURB. CURB MAY BE CONNECTED TO BUILDING FOUNDATION.
- ② EXISTING INLET/MANHOLE AND STORM DRAIN TO BE REMOVED.
- ③ EXISTING BOLLARD TO BE REMOVED. BOLLARD FOUNDATION SHALL REMAIN IN PLACE IF CONNECTED TO BUILDING FOUNDATION.
- ④ EXISTING SIGN POLE AND BASE TO BE REMOVED, SALVAGED AND STORED. EXISTING FOUNDATION SHALL REMAIN. FOUNDATION MAY BE CONNECTED TO BUILDING FOUNDATION.
- ⑤ DO NOT DISTURB.
- ⑥ EXISTING LIGHT POLE AND BASE TO BE REMOVED, SALVAGED AND STORED. EXISTING FOUNDATION SHALL BE REMOVED. FOUNDATION MAY BE CONNECTED TO BUILDING FOUNDATION.

NOTE: SOME FEATURES ARE CONNECTED TO THE BUILDING FOUNDATION. CONTRACTOR SHALL USE CAUTION WHILE DEMOLISHING EXISTING CURB, SIDEWALK, BOLLARDS AND SIGNS.

1	7/14/2023	REV. PER BPQS COMMENTS
△	DATE:	DESCRIPTION:

ORANGE STREET IMPROVEMENTS

PROJECT #:	23049
SCALE:	1"=10'
FORMAT:	30" X 42"
DRAWN:	WDK
CHECKED:	MPJ
DATE:	May 3, 2024

SHEET NAME:
DEMOLITION PLAN (N. ORANGE STREET)

SHEET NUMBER:
C-121
 NOT FOR CONSTRUCTION
 PROJECT PHASE:
CONSTRUCTION DOCUMENTS

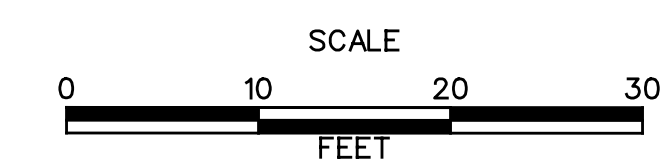

\\net\rkk.com\fa\Cloud\Projects\2023\23049-NB\N.Orange\Plans\CD\C121_CD_NBI.dgn
 11:00:35 AM

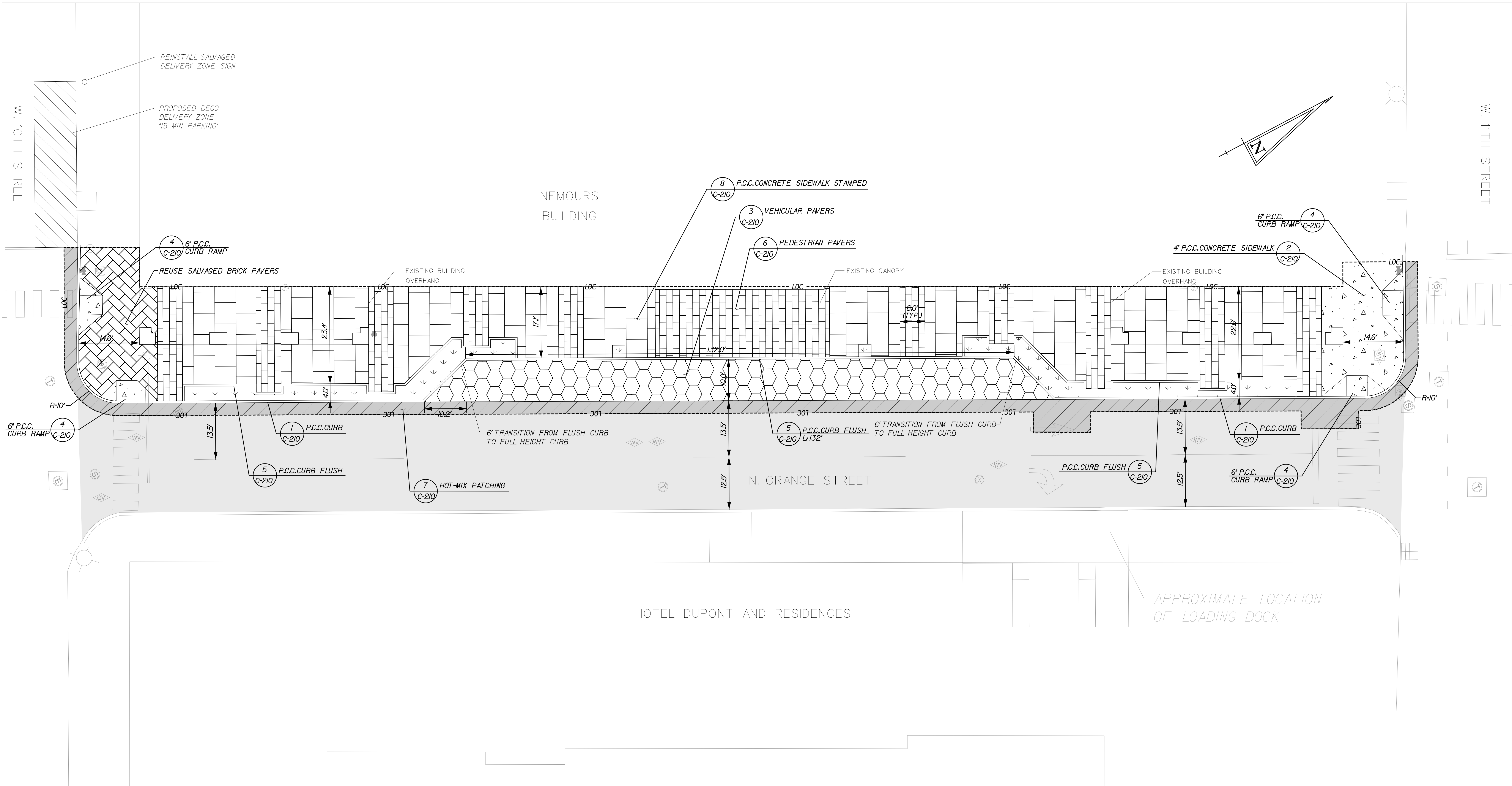

W. 11TH STREET

NEMOURS BUILDING

N. ORANGE STREET

HOTEL DUPONT AND RESIDENCES

APPROXIMATE LOCATION OF LOADING DOCK

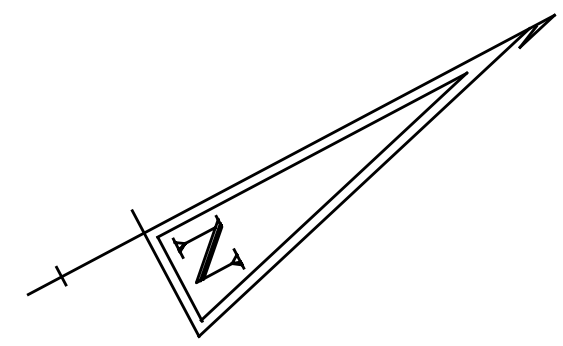

LEGEND

	PROPOSED CONCRETE PAVING
	PROPOSED STAMPED CONCRETE
	PROPOSED PEDESTRIAN PAVERS
	PROPOSED VEHICULAR PAVERS
	PROPOSED LANDSCAPING
	PROPOSED HOT-MIX PATCHING
	REUSE SALVAGED BRICK PAVERS

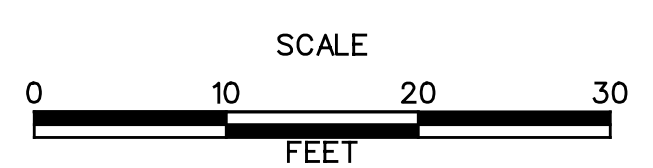

NOTES:

1. SEE SHEET C-210 FOR SITE DETAILS.
2. CONTRACTOR SHALL USE CAUTION WHEN SAW CUTTING / REMOVING EXISTING CURB TO PREVENT DAMAGE TO EXISTING BUILDING FOUNDATIONS
3. CURB RAMP SHALL CONFORM TO THE MOST RECENT DELDOT STANDARD CURB RAMP DETAIL C-2. CURB RAMP SHALL HAVE DETECTABLE WARNING SYSTEMS.
4. FOR MOT ASSOCIATED WITH THE WORK IN N. ORANGE STREET, THE CONTRACTOR SHALL APPLY DELDOT MUTCD TYPICAL APPLICATION 11B AND MODIFY IT FOR USE ON A ONE WAY STREET.
5. CONTRACTOR SHALL RESTRIPE STOP BAR, CROSSWALK LANE LINES AND LANE ARROWS IN EXISTING N. ORANGE STREET.

1	7/14/2023	REV. PER BPGS COMMENTS

ORANGE STREET IMPROVEMENTS

PROJECT #:	23049
SCALE:	1"=10'
FORMAT:	30" X 42"
DRAWN:	WDK
CHECKED:	MPJ
DATE:	May 3, 2024

SHEET NAME:
SITE PLAN (N. ORANGE STREET)

\\net\rk.com\Fa\Cloud\Projects\2023\23049_NBI\NBI\Cloud\Plans\CD\C201_CD_NBI.dgn
 11:00:35 AM

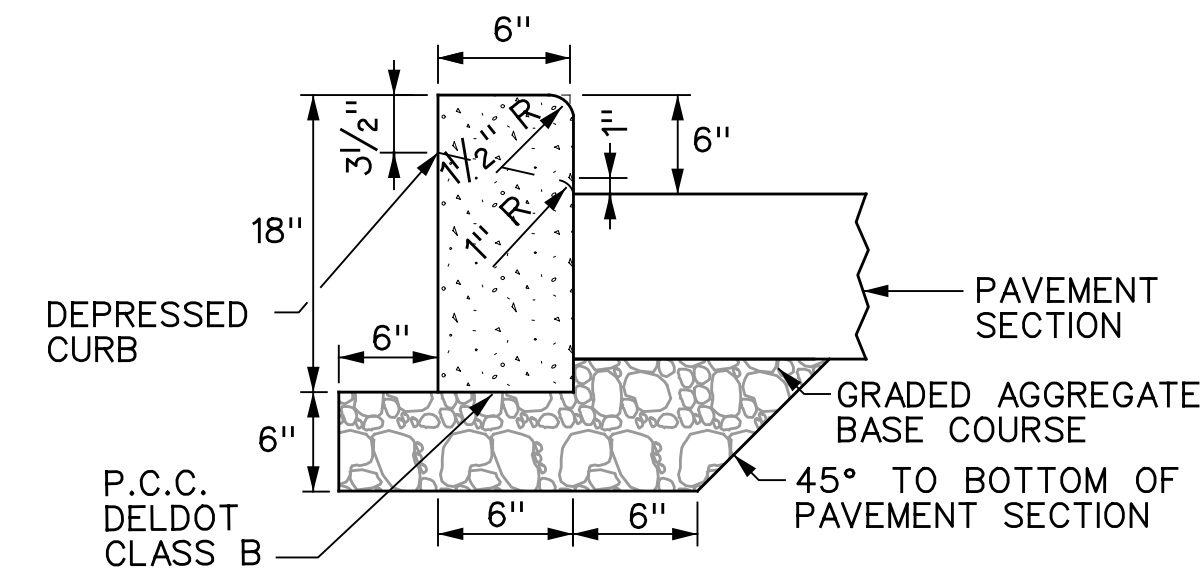

1
 C-210 6" P.C.C. CURB
 (6" H AND 6" W NO BATTER)
 N.T.S.

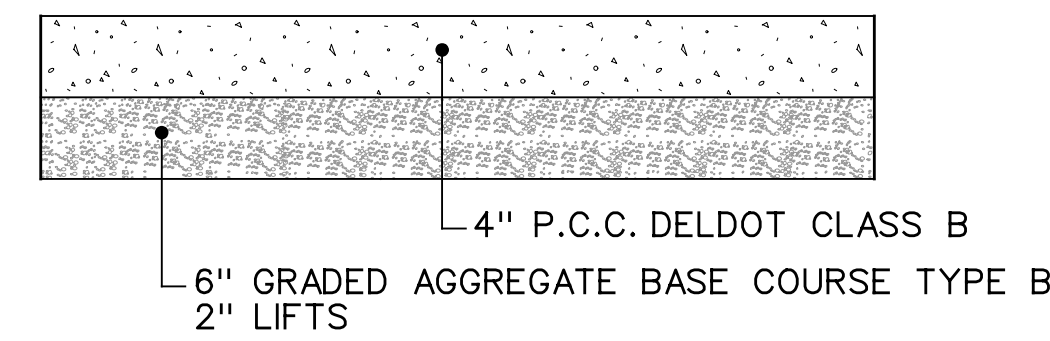

2
 C-210 4" P.C.C. PROPOSED SIDEWALK
 SECTION
 N.T.S.

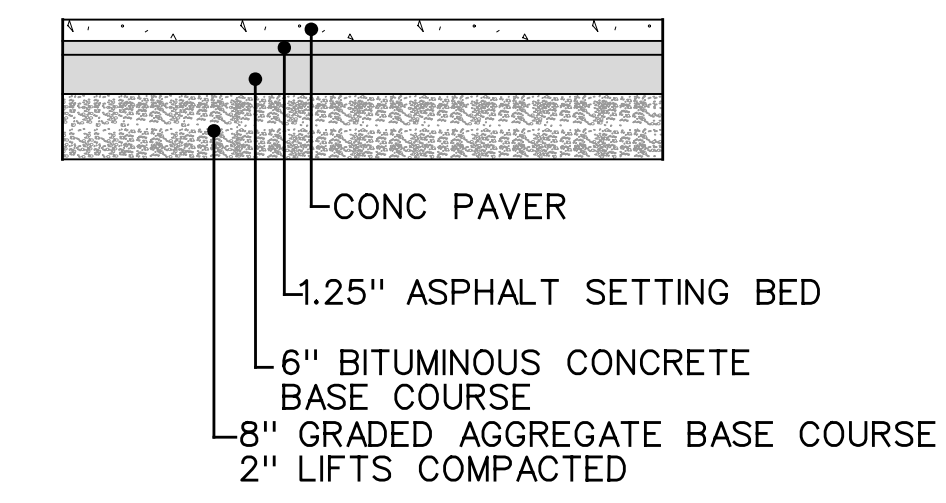

3
 C-210 VEHICULAR PAVER
 SECTION
 N.T.S.

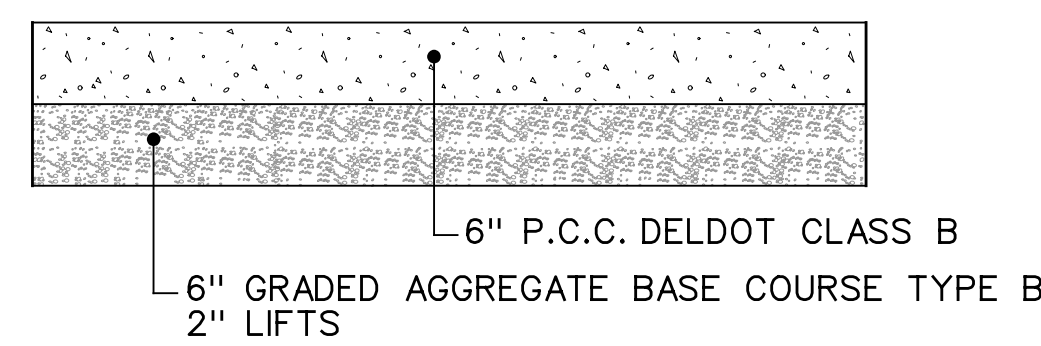

4
 C-210 6" P.C.C. PROPOSED CURB RAMP
 SECTION
 N.T.S.

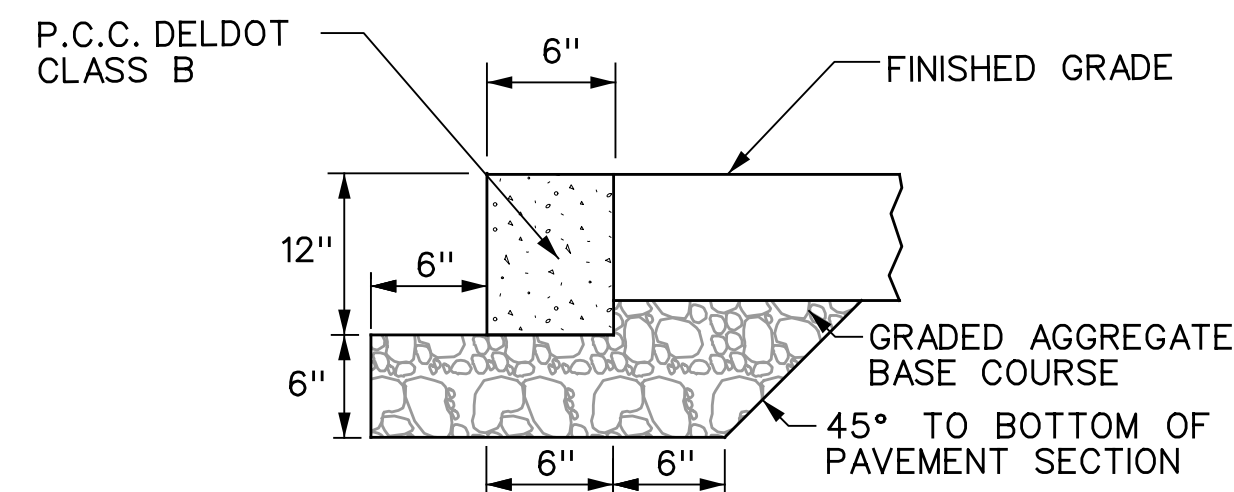

5
 C-210 P.C.C. CURB - FLUSH
 SECTION
 N.T.S.

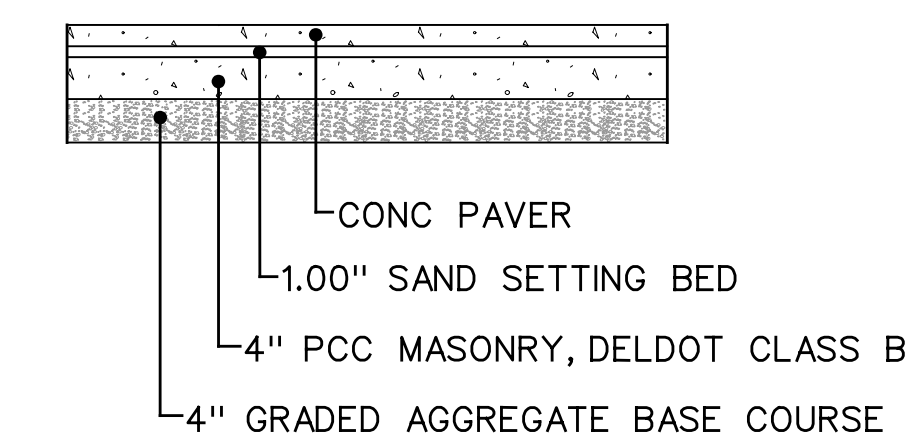

6
 C-210 PEDESTRIAN BRICK PAVER
 SECTION
 N.T.S.

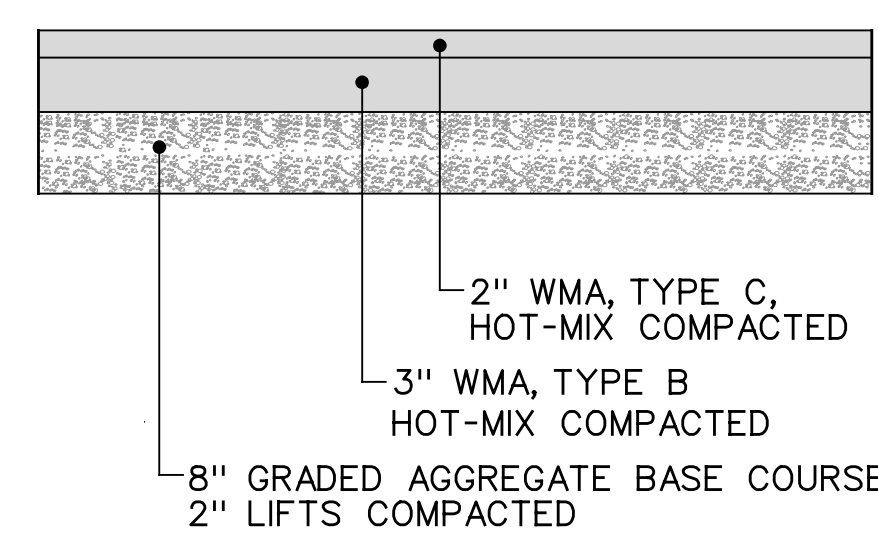

7
 C-210 HOT-MIX PATCHING
 SECTION
 N.T.S.

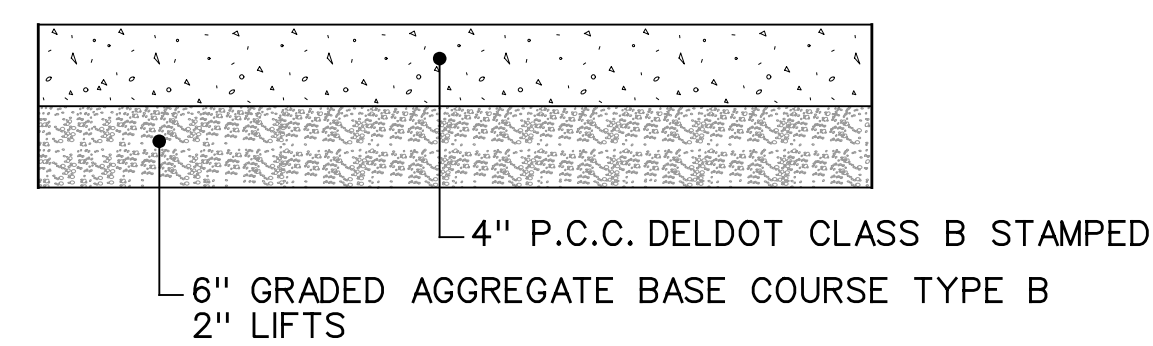

8
 C-210 4" P.C.C. PROPOSED SIDEWALK STAMPED
 SECTION
 N.T.S.

1	7/14/2023	REV. PER BPGS COMMENTS

**ORANGE STREET
 IMPROVEMENTS**

PROJECT #:	23049
SCALE:	N.T.S.
FORMAT:	30" X 42"
DRAWN:	WDK
CHECKED:	MPJ
DATE:	May 3, 2024

SHEET NAME:
**SITE
 DETAILS**

SHEET NUMBER:
C-210
 NOT FOR CONSTRUCTION
 PROJECT PHASE:
CONSTRUCTION DOCUMENTS

OWNER
 BPQS (BUCCINI | POLLIN GROUP)
 1000 N. West Street, Suite 850
 Wilmington, DE 19801
 v 302.691.2101

CIVIL ENGINEER
 RKK&K
 700 East Pratt Street, Suite 500
 Baltimore, MD 21202
 v 410.513.8521
 www.rkk.com

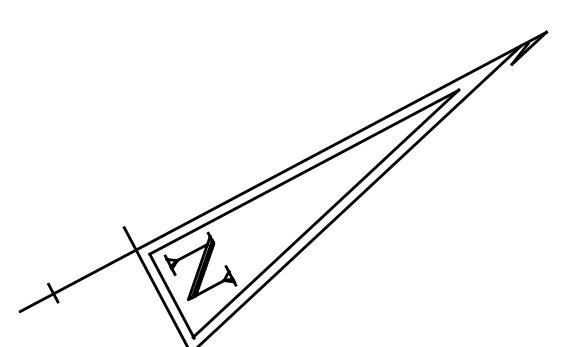
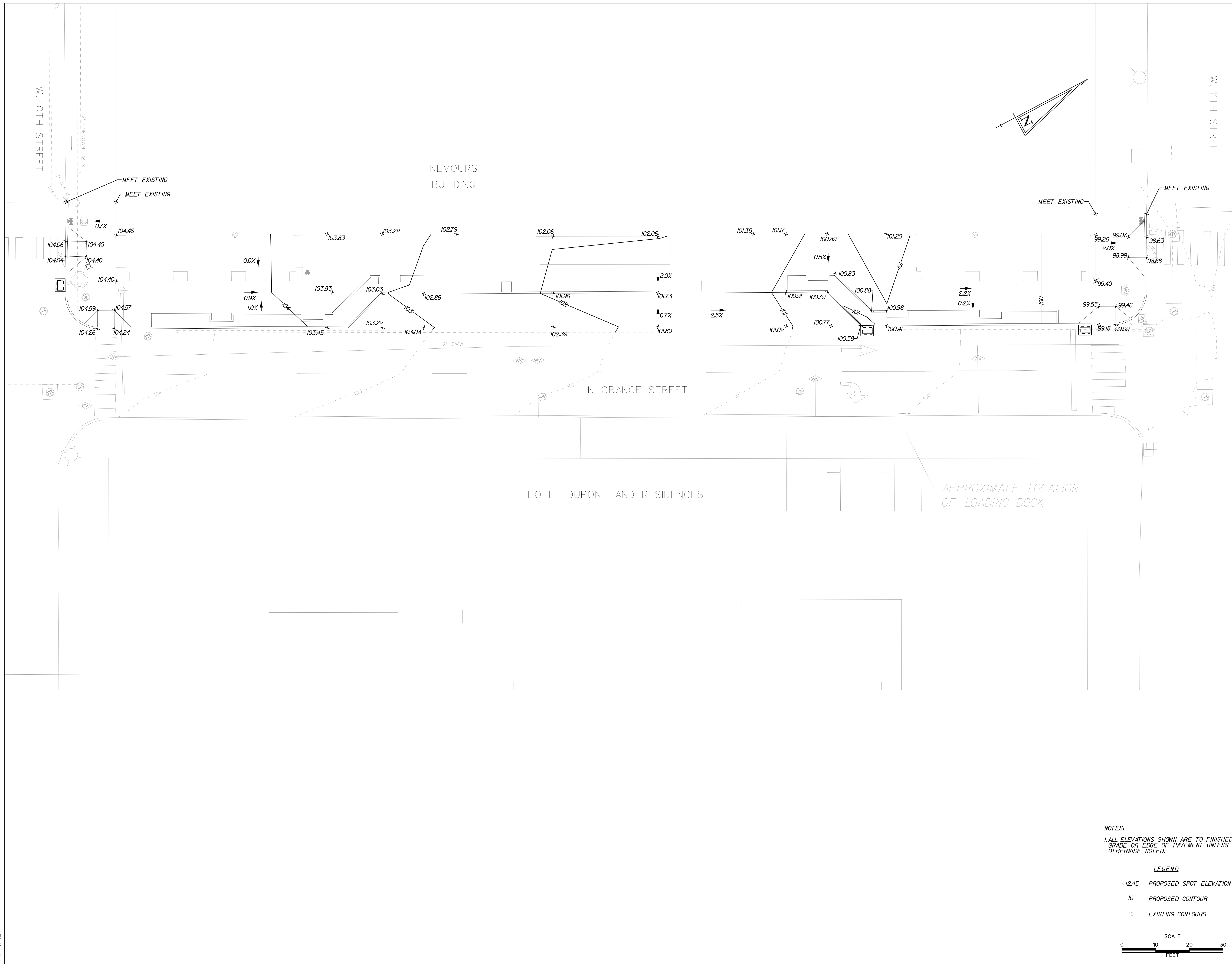

1	7/14/2023	REV. PER BPQS COMMENTS
△	DATE:	DESCRIPTION:

**ORANGE STREET
IMPROVEMENTS**

PROJECT #:	23049
SCALE:	1"=10'
FORMAT:	30" X 42"
DRAWN:	WDK
CHECKED:	MPJ
DATE:	May 3, 2024

SHEET NAME:
**GRADING PLAN (N.
ORANGE STREET)**

SHEET NUMBER:
C-301
 NOT FOR CONSTRUCTION
 PROJECT PHASE:
CONSTRUCTION DOCUMENTS

NOTES:
 1. ALL ELEVATIONS SHOWN ARE TO FINISHED GRADE OR EDGE OF PAVEMENT UNLESS OTHERWISE NOTED.

LEGEND

~12.45 PROPOSED SPOT ELEVATION
 — 10 — PROPOSED CONTOUR
 - - - - EXISTING CONTOURS

SCALE
 0 10 20 30
 FEET

\\net\rkk.com\Fa\Cloud\Projects\2023\23049-NBI\NBI\Cadd\Plans\CD\C301_CD_NBI.dgn
 11:00:35 AM

OWNER
BPGS (BUCCINI | POLLIN GROUP)
 1000 N. West Street, Suite 850
 Wilmington, DE 19801
 v 302.691.2101

CIVIL ENGINEER
RK&K
 700 East Pratt Street, Suite 500
 Baltimore, MD 21202
 v 410.913.8521
 www.rk.com

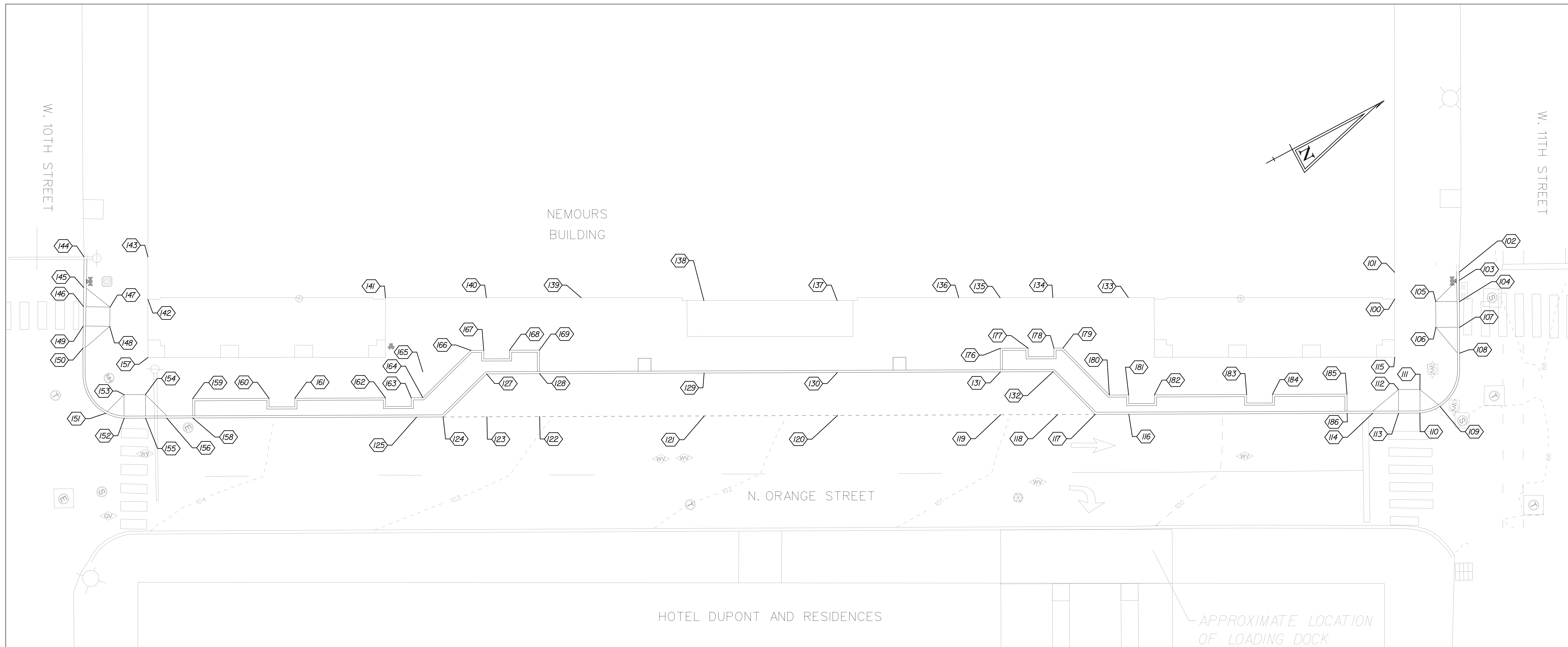

STAKEOUT DATA			
No.	NORTHING	EASTING	ELEVATION
100	636280.70	619054.29	99.40
101	636283.61	619048.75	MEET EX.
102	636296.96	619055.78	MEET EX.
103	636296.05	619057.49	MEET EX.
104	636293.73	619061.89	98.63
105	636288.87	619059.30	99.07
106	636286.09	619064.61	98.99
107	636290.93	619067.21	98.68
108	636288.15	619072.52	98.87
109	636278.28	619081.33	98.98
110	636273.43	619080.51	99.09
111	636276.01	619075.68	99.46
112	636271.59	619073.36	99.55
113	636269.04	619078.23	99.18
114	636263.68	619075.41	99.40
115	636274.30	619066.38	99.40
116	636213.37	619048.99	100.41
117	636206.45	619045.35	100.58
118	636198.69	619041.27	100.77
119	636186.90	619035.08	101.02
120	636153.28	619017.41	101.80
121	636125.79	619002.97	102.39
122	636091.81	618985.12	103.03
123	636080.93	618979.40	103.22
124	636071.88	618974.65	103.36
125	636066.43	618971.78	103.45
127	636085.58	618970.55	103.03
128	636096.46	618976.27	102.86
129	636130.44	618994.12	101.96
130	636157.93	619008.56	101.73
131	636191.55	619026.23	100.91
132	636202.43	619031.94	100.81
133	636226.02	619024.89	101.20
134	636210.48	619016.65	101.89
135	636199.61	619010.89	101.17
136	636191.00	619006.37	101.35
137	636165.74	618993.69	102.06
138	636138.30	618979.15	102.06
139	636133.34	618965.16	102.79
140	636093.83	618954.81	103.22
141	636073.05	618943.79	103.90
142	636205.36	618918.17	104.46
143	636028.61	618909.44	MEET EX.
144	636015.46	618902.46	MEET EX.
145	636012.03	618908.75	104.07
146	636009.92	618912.61	104.06
147	636015.32	618915.66	104.40
148	636013.14	618919.59	104.40
149	636007.72	618916.65	104.04
150	636005.26	618921.15	104.02

STAKEOUT DATA			
No.	NORTHING	EASTING	ELEVATION
151	636002.86	618937.06	104.28
152	636006.09	618940.08	104.26
153	636008.63	618935.21	104.59
154	636013.05	618937.53	104.57
155	636010.50	618942.40	104.24
156	636014.86	618944.70	104.15
157	636017.60	618930.22	104.40
158	636020.23	618947.52	104.09
159	636022.33	618943.53	104.52
160	636038.09	618951.81	104.30
161	636043.40	618954.60	104.24
162	636062.11	618964.43	103.97
163	636067.42	618967.22	103.90
164	636069.82	618968.48	103.87
165	636072.65	618963.12	103.83
166	636084.89	618963.97	103.47
167	636087.54	618965.37	103.38
168	636092.85	618968.16	103.13
169	636099.02	618971.40	102.92
176	636194.11	619021.36	100.99
177	636199.87	619024.38	100.92
178	636205.18	619027.17	100.83
179	636207.04	619028.15	100.83
180	636211.45	619042.89	100.88
181	636215.46	619045.00	100.98
182	636220.77	619047.79	100.85
183	636239.80	619057.78	100.39
184	636245.11	619060.57	100.26
185	636260.50	619068.66	99.87
186	636258.41	619072.64	99.52

NOTES:
 1. ALL ELEVATIONS SHOWN ARE TO FINISHED GRADE OR EDGE OF PAVEMENT UNLESS OTHERWISE NOTED.

NOTES:
 1. ALL ELEVATIONS SHOWN ARE TO FINISHED GRADE OR EDGE OF PAVEMENT UNLESS OTHERWISE NOTED.

LEGEND

- 12.45 PROPOSED SPOT ELEVATION
- 10- PROPOSED CONTOUR
- - - - - EXISTING CONTOURS

SCALE
 0 10 20 30
 FEET

1	7/14/2023	REV. PER BPGS COMMENTS

ORANGE STREET IMPROVEMENTS

PROJECT #:	23049
SCALE:	1"=10'
FORMAT:	30" X 42"
DRAWN:	WDK
CHECKED:	MPJ
DATE:	May 3, 2024

SHEET NAME:
GRADING STAKEOUT PLAN (N. ORANGE STREET)

SHEET NUMBER:
C-311
 NOT FOR CONSTRUCTION
 PROJECT PHASE:
CONSTRUCTION DOCUMENTS

\\drk\k.com\fa\Cloud\Projects\2023\23049-NB\N-Cadd\Plans\CD\C311_CD_NBI.dgn
 11:00:36 AM

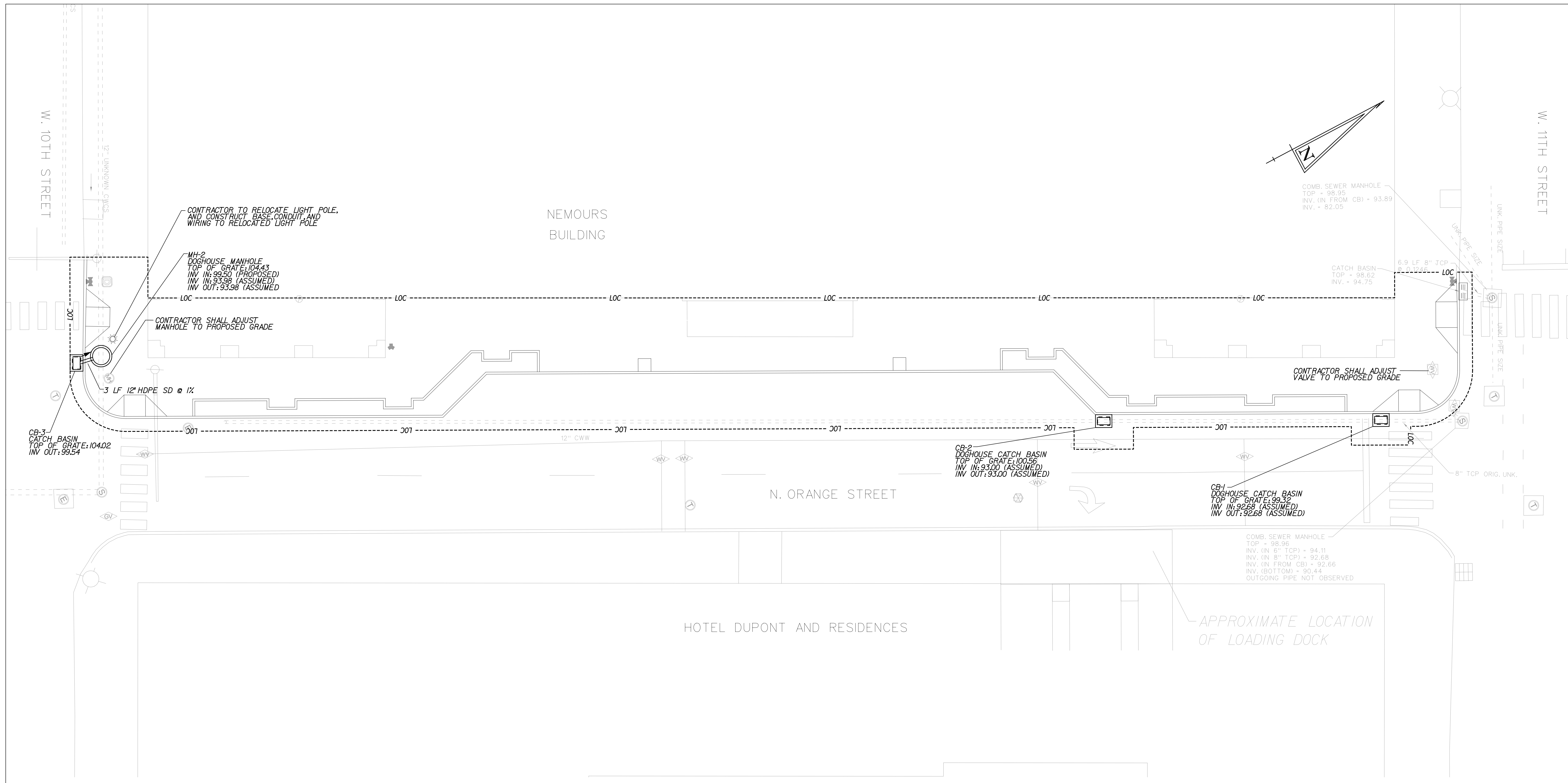

STORM DRAIN NOTES:

1. STORM DRAIN STRUCTURES AND PIPE INSTALLATION SHALL CONFORM TO THE MOST RECENT DELDOT STANDARD DETAILS:
 - a. DOGHOUSE MANHOLE: STD. DETAIL D-4 TO D-6
 - b. INLETS: D-4, D-5 & D-R
 - c. PIPE BEDDING: STD. DETAIL D-8
 - d. PIPE PLUGGING: STD. DETAIL D-10
 - e. STEEL PLATE: STD. DETAIL M-1
 - f. PERMANENT CROSS ROAD PATCH OVER PIPE: STD. DETAIL P-4

GENERAL UTILITY NOTES:

1. PRIOR TO THE START OF UTILITY CONSTRUCTION, THE CONTRACTOR SHALL SCHEDULE A PRECONSTRUCTION MEETING BETWEEN THE ENGINEER, EACH UTILITY COMPANY AND BPG TO CONFIRM SERVICE LOCATION AND EACH UTILITY'S REQUIREMENTS.
2. ALL EXISTING UTILITIES TAKEN FROM PROVIDED MAPPING AND FIELD LOCATIONS WHERE POSSIBLE, CONTRACTOR TO VERIFY ALL UTILITIES IN THE FIELD PRIOR TO EXCAVATING, AND/OR CROSSING/CONNECTING THERE TO EXISTING UTILITIES ARE SHOWN IN ACCORDANCE WITH THE BEST AVAILABLE INFORMATION. THE CONTRACTOR IS FULLY RESPONSIBLE FOR LOCATING ALL UTILITIES IN THE AREA OF CONSTRUCTION AND IS FULLY RESPONSIBLE FOR REPAIRS TO UTILITIES DAMAGED AS A RESULT OF PROJECT CONSTRUCTION ACTIVITIES. THE CONTRACTOR SHALL NOTIFY THE CONSTRUCTION MANAGER IMMEDIATELY OF ALL UTILITIES DAMAGED BY PROJECT CONSTRUCTION.
3. TEST PITS ARE REQUIRED ON THIS PROJECT TO LOCATE ALL EXISTING UNDERGROUND UTILITIES. THE CONTRACTOR, PRIOR TO LAYING A RUN OF PIPE OR EXCAVATING FOR ANY UTILITY APPURTENANCE, SHALL EXCAVATE WITHIN THE ALIGNMENT AT POINTS OF POSSIBLE CONFLICT TO DETERMINE IF A CONFLICT EXISTS. ANY CONFLICTS SHALL BE COORDINATED BY THE CONTRACTOR WITH THE ENGINEER AND THE CONSTRUCTION MANAGER TO DETERMINE A SOLUTION.
4. UNLESS OTHERWISE SPECIFIED, ALL EXISTING PIPES SHALL REMAIN IN PLACE. PIPES THAT ARE NOT INTENDED FOR CONTINUED USE SHALL BE PLUGGED.
5. FOR UTILITY DETAILS SEE SHEETS C-40

STORM DRAIN STRUCTURE SCHEDULE

NO.	TYPE	TOP	GRATE	RIM ELEV.	INVERT IN	INVERT OUT	NORTHING	EASTING
CB-1	DOGHOUSE CATCH BASIN 3' X 2'	TYPE C	TYPE I	99.32	EX. 8" TC* (SW) 92.68	EX. 8" TC* (NE) 92.68	636264.58	619077.68
CB-2	DOGHOUSE CATCH BASIN 3' X 2'	TYPE C	TYPE I	100.56	EX. 8" TC* (SW) 93.00	EX. 8" TC* (NE) 93.00	636207.42	619047.55
CB-3	3' X 2'	TYPE C	TYPE I	104.02	N/A	12" HDPE (NE) 99.54	636002.36	618923.35

* EXISTING INVERT IS APPROXIMATE. CONTRACTOR SHALL FIELD VERIFY PRIOR TO ORDERING PROPOSED STORM PIPES/DOGHOUSE CATCH BASINS/DOGHOUSE MANHOLES.

SANITARY STRUCTURE SCHEDULE

NO.	TYPE	GRATE/COVER	RIM ELEV.	INVERT IN	INVERT OUT	NORTHING	EASTING
MH-2	48" DOGHOUSE MANHOLE	STANDARD COVER	104.43	EX. 12" TC* (NW) 93.98 12" HDPE (SW) 99.50	EX. 12" TC* (SE) 93.98	636008.16	618924.72

* EXISTING INVERT IS APPROXIMATE. CONTRACTOR SHALL FIELD VERIFY PRIOR TO ORDERING PROPOSED SANITARY PIPES/DOGHOUSE MANHOLE.

UTILITY OWNERS LIST

UTILITY	TELEPHONE NUMBER
DELMARVA POWER DELIVERY (ELECTRIC)	(302) 454-4370
DELMARVA POWER DELIVERY (GAS)	(302) 429-3222
VERIZON-DE, INC.	(610) 280-5574
COMCAST	(302) 661-4435
CITY OF WILMINGTON WATER	(302) 576-3060
CITY OF WILMINGTON SEWER	(302) 576-3060

LEGEND

- EXISTING**
- 8" CWW - CITY OF WILMINGTON WATER
 - ELEC - DELMARVA ELECTRIC
 - GAS - DELMARVA GAS
 - 10" CWS - CITY OF WILMINGTON STORM DRAIN
 - 16" CWS - CITY OF WILMINGTON COMBINED SANITARY SEWER
 - VER - VERIZON
- PROPOSED**
- 10" SD - STORM DRAIN
 - CATCH BASIN

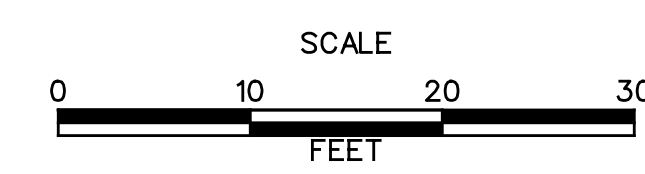

1	7/14/2023	REV. PER BPGS COMMENTS

ORANGE STREET IMPROVEMENTS

PROJECT #:	23049
SCALE:	1"=10'
FORMAT:	30" X 42"
DRAWN:	WDK
CHECKED:	MPJ
DATE:	May 3, 2024

**SHEET NAME:
 UTILITY COMPOSITE PLAN (N. ORANGE STREET)**

**SHEET NUMBER:
 C-401**
 NOT FOR CONSTRUCTION
 PROJECT PHASE:
CONSTRUCTION DOCUMENTS

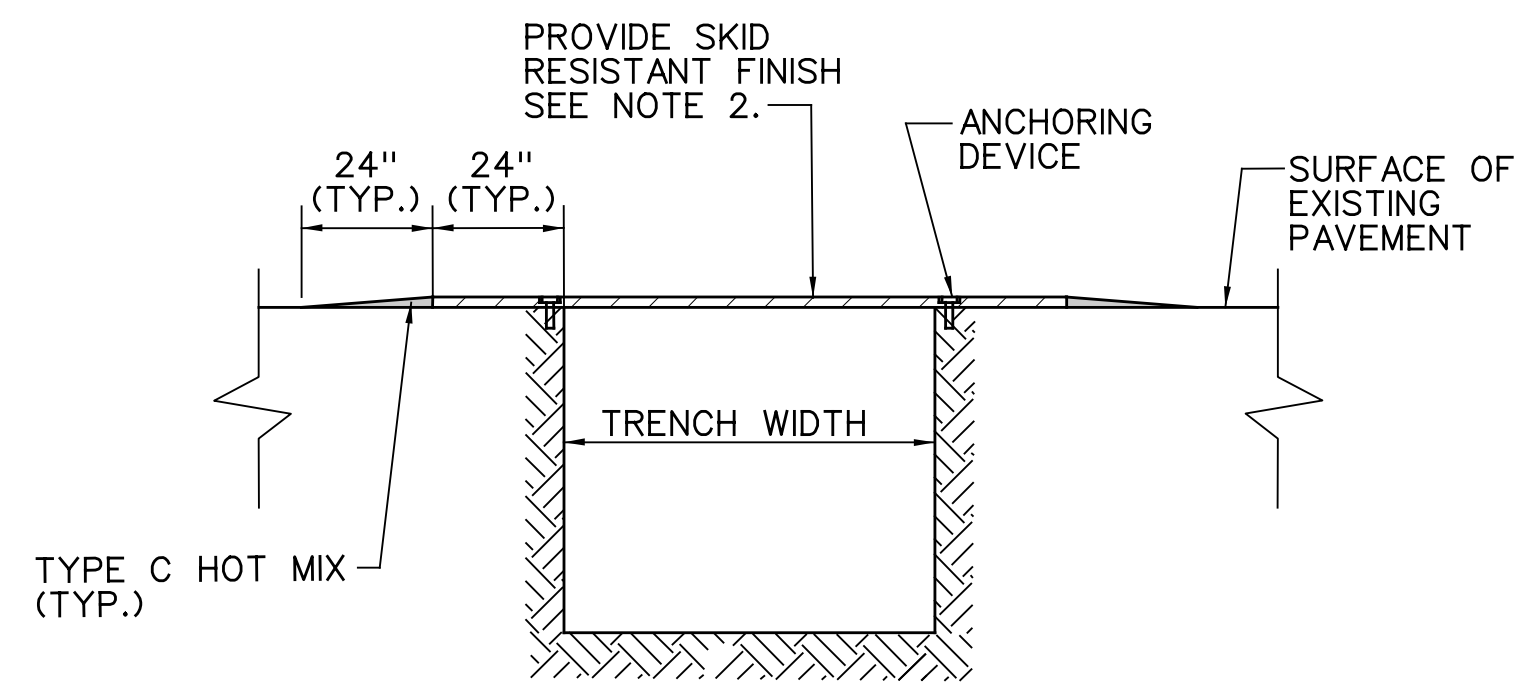

STEEL PLATE NOTES:

1. TO MAINTAIN TRAFFIC AND SAFETY, STEEL PLATES SHALL BE PERMITTED TO TEMPORARILY BRIDGE TRENCH EXCAVATIONS. THE STEEL PLATES SHALL BE OF SIZE TO ADEQUATELY CARRY A LOADING OF HS25 WITHOUT DETRIMENTAL DEFLECTION AS DETERMINED BY THE ENGINEER. THE DESIGN AND DETAILS SHALL BE PREPARED AND SIGNED BY A PROFESSIONAL ENGINEER REGISTERED IN DELAWARE, AND SHALL BE SUBMITTED TO THE ENGINEER FOR APPROVAL PRIOR TO FURNISHING PLATES TO THE PROJECT SITE. THE DESIGN AND DETAILS SHALL INCLUDE PLATE THICKNESS, METHOD OF FASTENING PLATES, SPAN, BEARING, SUPPORT OF EXCAVATION METHOD (E.G. SHEETING, SHORING, BRACING, ETC.) AND METHOD OF PREVENTING MOVEMENT OF PLATES. THE PLATES SHALL BE FITTED IN PLACE IN A MANNER SO AS TO MINIMIZE NOISE WHEN CROSSED BY TRAFFIC.
2. ALL PLATING USED TO COVER EXCAVATED AREAS SHALL BE PICKLED, ETCHED AND/OR ABRASIVELY COATED TO REDUCE THE EXTENT OF VEHICLE SLIDING UPON BRAKE APPLICATION. METHOD(S) OF ACHIEVING PLATE ABRASIVE TEXTURE SHALL BE SUBMITTED FOR THE ENGINEER'S APPROVAL PRIOR TO FURNISHING PLATES TO THE PROJECT SITE.
3. THE COST OF FURNISHING, PLACING, MAINTAINING AND REMOVING THE PLATES, FOR ALL LABOR, TOOLS, EQUIPMENT, HOT MIX AND NECESSARY INCIDENTALS TO COMPLETE THE JOB SHALL BE INCLUDED IN THE BASE BID.

STEEL PLATE DETAIL

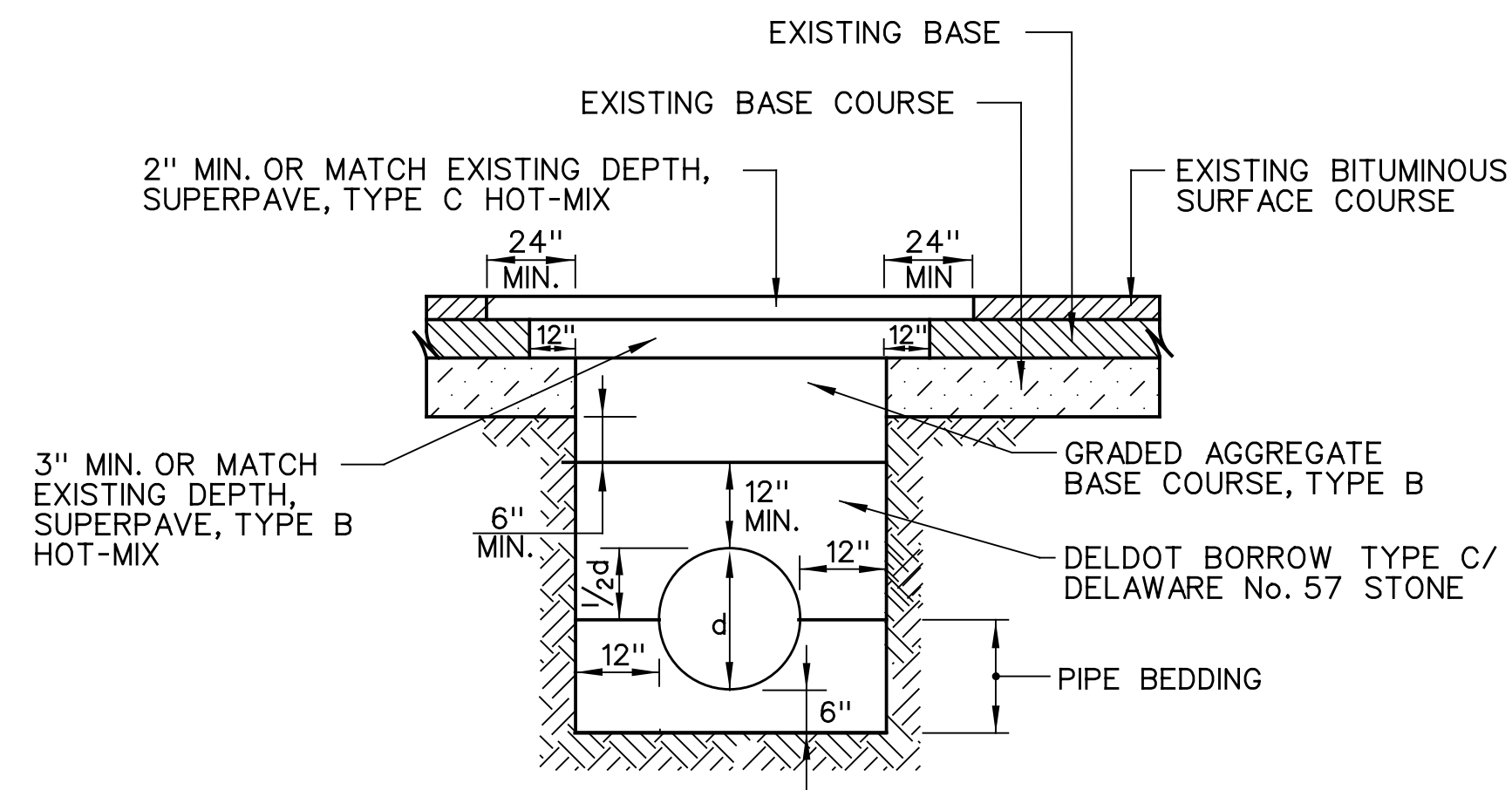

ROADWAY PAVEMENT PATCHING SECTION & TRENCH DETAIL FOR PAVED AREAS

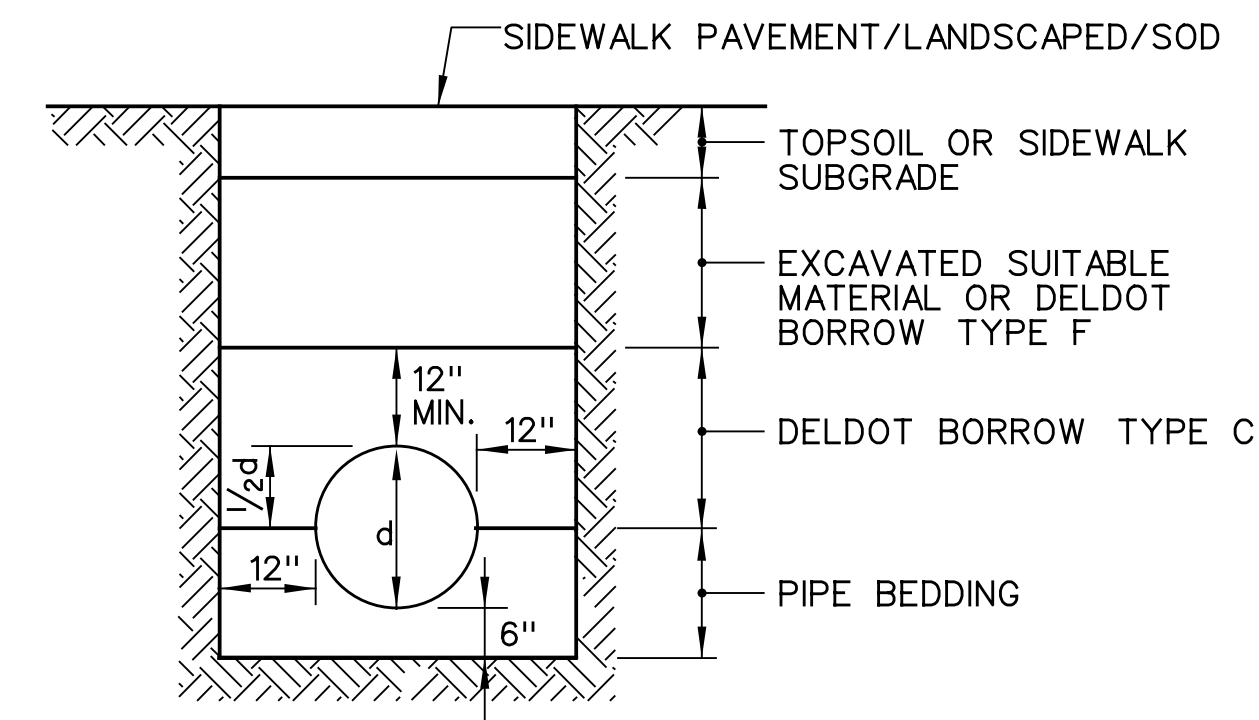

TRENCH DETAIL FOR SIDEWALK OR LANDSCAPED AREAS

PIPE TRENCH NOTES:

1. EXCAVATION AND BACKFILL SHALL BE IN ACCORDANCE WITH SECTION 208 OF THE STATE OF DELAWARE STANDARD SPECIFICATIONS.
2. THE ENGINEER SHALL DETERMINE WHAT PORTION, IF ANY, OF THE EXCAVATED MATERIAL IS SUITABLE FOR BORROW TYPE F OR BORROW TYPE C.
3. COMPACTION SHALL MEET OR EXCEED 95%.
4. ALL DIMENSIONS ARE SHOWN IN INCHES AND ARE TO THE OUTSIDE WALL OF PIPES/DUCTS.
5. WHERE A STEEL PLATE IS USED WITH A PIPE TRENCH DETAIL, THE LIMITS OF SUPERPAVE, TYPE C HOT-MIX, SHALL BE MODIFIED AS SHOWN ON THE STEEL PLATE DETAIL.
6. COMMON TRENCHES ARE PERMITTED, A MINIMUM OF 2' CLEAR BETWEEN THE OUTSIDE WALLS OF THE PIPES/DUCTS OR CONCRETE ENCASEMENT IS REQUIRED.
7. COMPACTION TESTS MUST BE PROVIDED AT THE SPRING LINE OF THE PIPE BETWEEN THE TWO UTILITIES TO ENSURE COMPACTION.

TYPICAL TRENCH DETAILS

OWNER
BPGS (BUCCINI | POLLIN GROUP)
 1000 N. West Street, Suite 850
 Wilmington, DE 19801
 v.302.691.2101

CIVIL ENGINEER
RK&K
 700 East Pratt Street, Suite 500
 Baltimore, MD 21202
 v.410.913.8521
 www.rk.com

1	7/14/2023	REV. PER BPGS COMMENTS
△	DATE:	DESCRIPTION:

ORANGE STREET IMPROVEMENTS

PROJECT #:	23049
SCALE:	N.T.S.
FORMAT:	30" X 42"
DRAWN:	WDK
CHECKED:	MPJ
DATE:	May 3, 2024

SHEET NAME:
UTILITY DETAILS

SHEET NUMBER:
C-410
 NOT FOR CONSTRUCTION
 PROJECT PHASE:
CONSTRUCTION DOCUMENTS

\\net\rk.com\Fa\Cloud\Projects\2023\23049_NBI\Cadd\Plans\CD\C410_cd_NBI.dgn
 11:00:40 AM